

TIF TRIFLOW CONCEPTS



TRIFLOW 03

NEW for 2021!



TRIFLOW O3 WATER

How is O3 water made?

Ozone is a natural gas, a tri-atomic form of Oxygen.

It is produced in the Ozone Generator which is supplied with air and a little bit of electricity.

The electricity splits the Oxygen in the air into two Oxygen atoms. The Oxygen atoms combine with Oxygen molecules to form the Ozone gas.

The weak bond holding Ozone's third Oxygen atom is what causes Ozone to be a very strong Oxidant and an ideal 'Chemical free' sanitizer and oxidizer agent.

When oxidizing a compound, it loses the weakly bonded atom, and an oxygen molecule remains.



O3 Anti-Bacterial Properties

O3 is 3,000 times more powerful than traditional oxidants such as chlorine. It has no toxicity issues and produces no by products. Micro organisms do not build up a tolerance to O3. O3 can eliminate a wide variety of inorganic, organic, microbiological, taste and odour problems.

The efficacy of Triflow O3 Water to destroy pathogens is dependant on the O3 concentration in water and the contact or 'treatment' time. The sanitizing ability of Triflow O3 Water increases as either or both variable is increased.

Independent testing by Internationally recognized Labs such as TÜV have upheld all claims made on the NEW Triflow O3 systems

Safety

O3 is produced in the Generator; because of its 'short life' (as it reverts back to Oxygen) O3 cannot be supplied or stored in tanks.

O3 has been allowed and accepted for some time in food processing in Japan, Australia, New Zealand and other countries. O3 was confirmed as GRAS (Generally Recognised as Safe) by the FDA in 1998 and recently as a safe and sustainable sanitizer for food meant for human consumption.

O3 Benefits

- Over 99.99% of microbes and Viruses will be removed,
- Leaving you with clean hands and surfaces with no chemicals required
- Removes odours from fish, garlic, smoke, etc, just with Ozonized water.
- O3 water can preserve food for up to 2-3times longer
- Simply press the O3 button or activate the sensor to start dispensing O3 water.
- No change in the water flow rate or temperature.
- The O3 generator will automatically stop if not used for more than 10 mins.
- 2 Years Guarantee on both Generator and Tap

O3 Approvals

is approved by the Food and Drug Administration in the USA.

All components in Triflow O3 Taps are WRAS compliant.



O3 Awards

Triflow O3 has already gained the following design awards.



IDEA Design Award – Gold Winner



Good Design Award – Winner

NEW FOR 2021 TRIFLOW 03

NEW FOR 2021 TRIFLOW 03



Triflow 03 Mixer

Product Code: TF-03-KITCHEN

KEY FEATURES:

Mixer

- 3 in 1 system incorporating Hot, Cold and O3 water
- O3 water by the touch of a button
- Pull out spray head
- 360-degree rotating spout
- Solid brass construction with deep protective coating
- Available in Chrome

Generator

- Slimline design
- Mains power operated
- Space saving installation feature
- Available in White

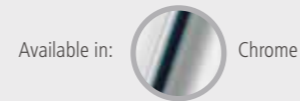

Triflow 03 Sensor

Product Code: TF-03-SENSOR

KEY FEATURES:

Sensor

- O3 specific system
- Motion infrared sensor activation
- Solid brass construction with deep protective coating
- Available in Chrome

Generator

- Slimline design
- Mains power operated
- Space saving installation feature
- Available in White

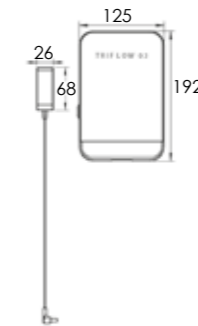
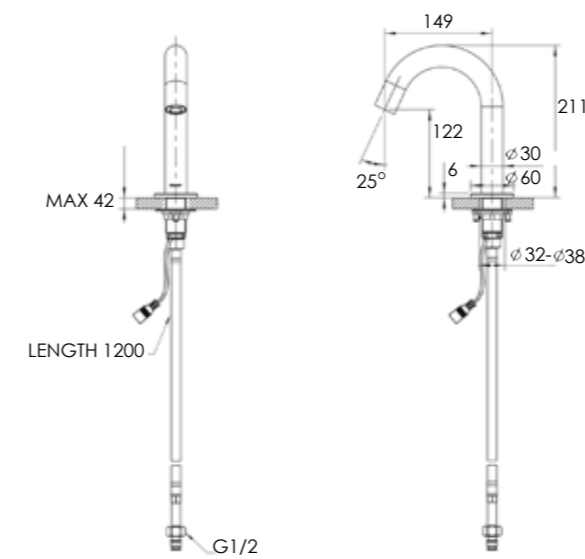
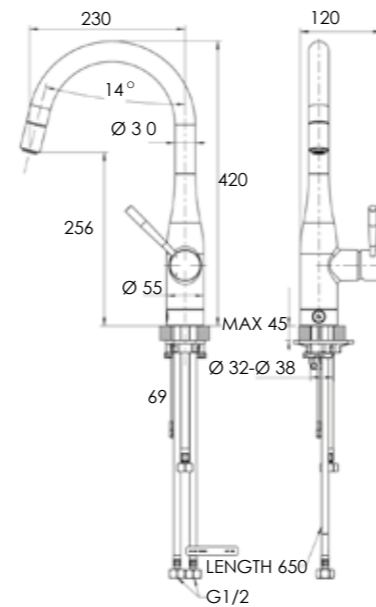
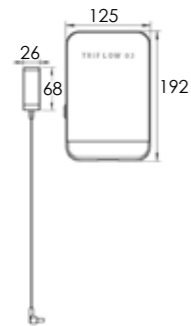
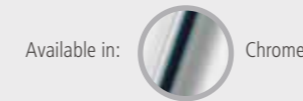



TAP INTO A HEALTHY LIFESTYLE

Triflow Concepts Ltd, Global House, 95 Vantage Point, Pensnett Trading Estate, Kingswinford, West Midlands DY6 7FT

www.triflowconcepts.com | info@triflowconcepts.com | Tel: 0800 999 3959